

Schiebemuttern / slide nuts
M6 (3x je Seite/each side)
max. Einschraubtiefe / tap depth 6mm

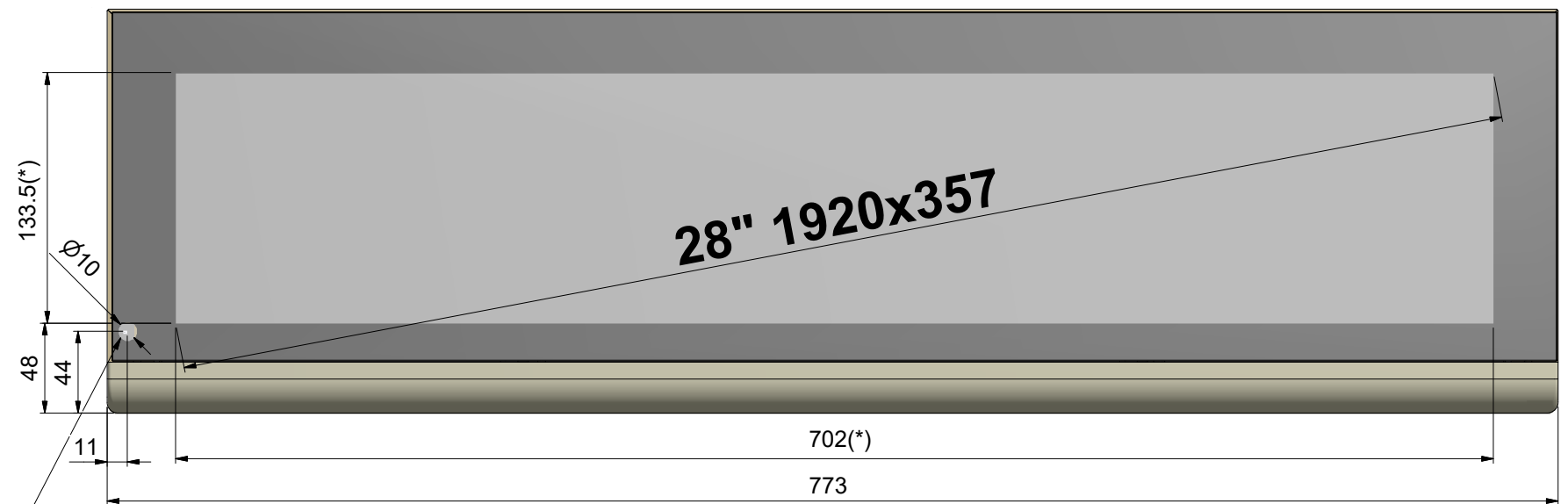

Helligkeits- / Dimming- Sensor

Stecker / connector
(ohne Abdeckung dargestellt/
without cover - plate)

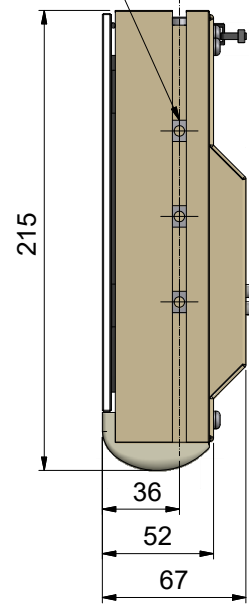
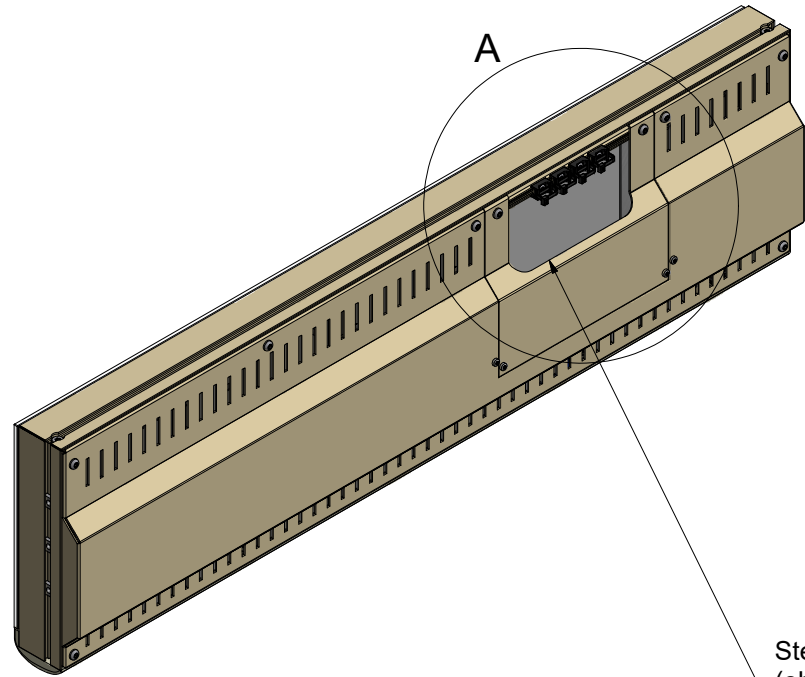
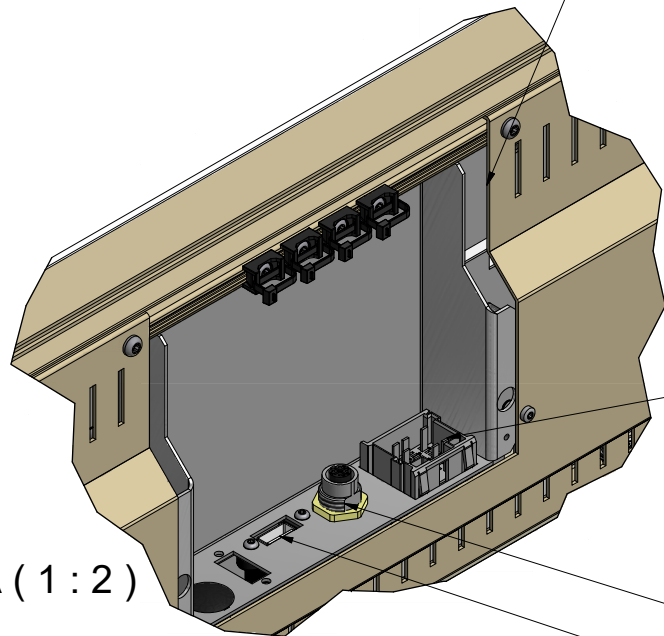
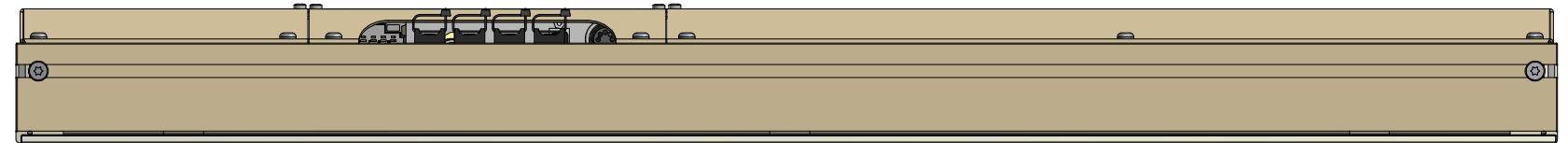

15pol.MCP-Stecker
male connector

1	24V DC
2	NC
3	0V DC
4	shield
5	NC
6	NC
7	NC
8	NC
9	NC
10	NC
11	NC
12	NC
13	NC
14	NC
15	NC

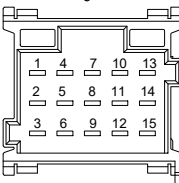
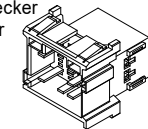

A (1:2)

(M12) IP / Ethernet

USB

Betriebsspannung / Operating voltage: 24V, typ 1,5A
Lackierung / colour: eloxiert EL 25.3
Deckel / cover: eloxiert EL 25.3
Gewicht / weight: 7,2 kg
(*) = Sichtfeld / view area
Betriebstemp.bereich / operating temp . range: 0°C - +50°C

Sachnummer/partnumber:

EMV: Typgenehmigungspflichtig nach EMV-Richtlinie 72/245/EWG bzw. ECE Regelung Nr. 10
EMI: Requiring official approval in accordance with EMI-Guideline 72/245/EC and ECE-Regulation N°. 10 respectively

Brennverhalten von Materialien: Nach ECE-Regelung Nr. 118
Burning Behaviour: In accordance with ECE-Regulation N°. 118

SCHUTZVERMERK NACH ISO 16016 PROTECTIONMARK ISO 16016		DIN ISO 2768-1 fein mittel grob fine medium coarse	MATERIAL:	Maßstab/scale:0,4:1 (1:4,1:2)
		Datum/date: 20.04.2018	Name/name: ab	MobiSCREEN 28", IP/Ethernet,1.920x357
				TH09C0005-100
Index No.	Anderungen revision	Datum date	Name name	Blatt / page 1 / 1 FORMAT A2
		TNR.: ENG-043360.iam		ZNR.:ENG-045268.idw